

## NivuFlow 600

Transit Time Flow Measurement for clean to slightly polluted Media in Full Pipes

new

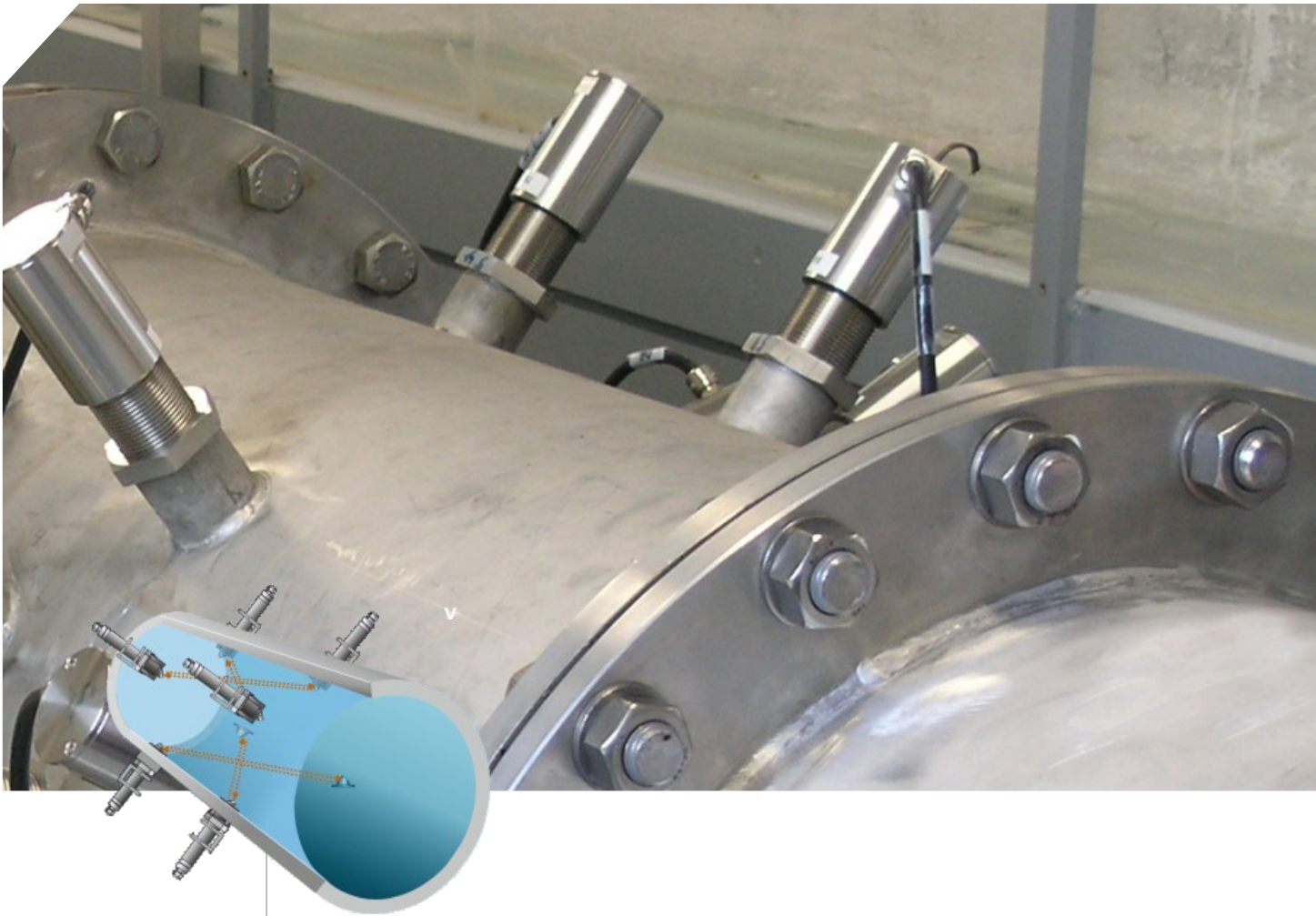

## Perfect flow measurement in full pipelines Insert or clamp-on

The NivuFlow 600 system was developed particularly for flow measurement in full pipes. To meet the highest accuracy requirements it is possible to equip the transmitters with up to 4 measurement paths. There are pipe sensors as well as contactless clamp-on sensors available for the measurement system. It is not necessary to interrupt running processes to install both sensor types. The system is suitable for the detection of flow rates in various liquid media covering a wide range of applications.



## Flow measurement systems at the highest technical level

The enclosure is significantly smaller than earlier devices and can be easily integrated into switching cabinets saving space thanks to DIN rail mounting.

Moreover, the NivuFlow 600 units are available in a special field enclosure for use in rough environmental conditions.

The transmitter's large graphic display allows quick and easy commissioning of the flow metering system.

It furthermore provides extended diagnostic options and enables in-depth analyses of running processes on site.

The transmitter software was newly developed from scratch. Using future-proof protocols and versatile options for communication and connections opens a wide variety of options to operators when it comes to integrate the instruments into higher systems such as SCADA or process conducting systems.

### Your benefits

- Ultrasonic transit time measurement
- Single or multi path measurement
- Intuitive, modern operating concept for quick and easy initial start-up
- Insert or clamp-on-sensors available
- Online connection/data transmission and remote maintenance via Internet
- Easy to integrate into existing control systems through universal interfaces
- Weatherproof version for outdoor use available



### Typical Applications

Process water in pipes, cooling water and circulation systems, hydropower plants, penstock monitoring, turbine efficiency monitoring

## Transit Time - How the NivuFlow 600 measures

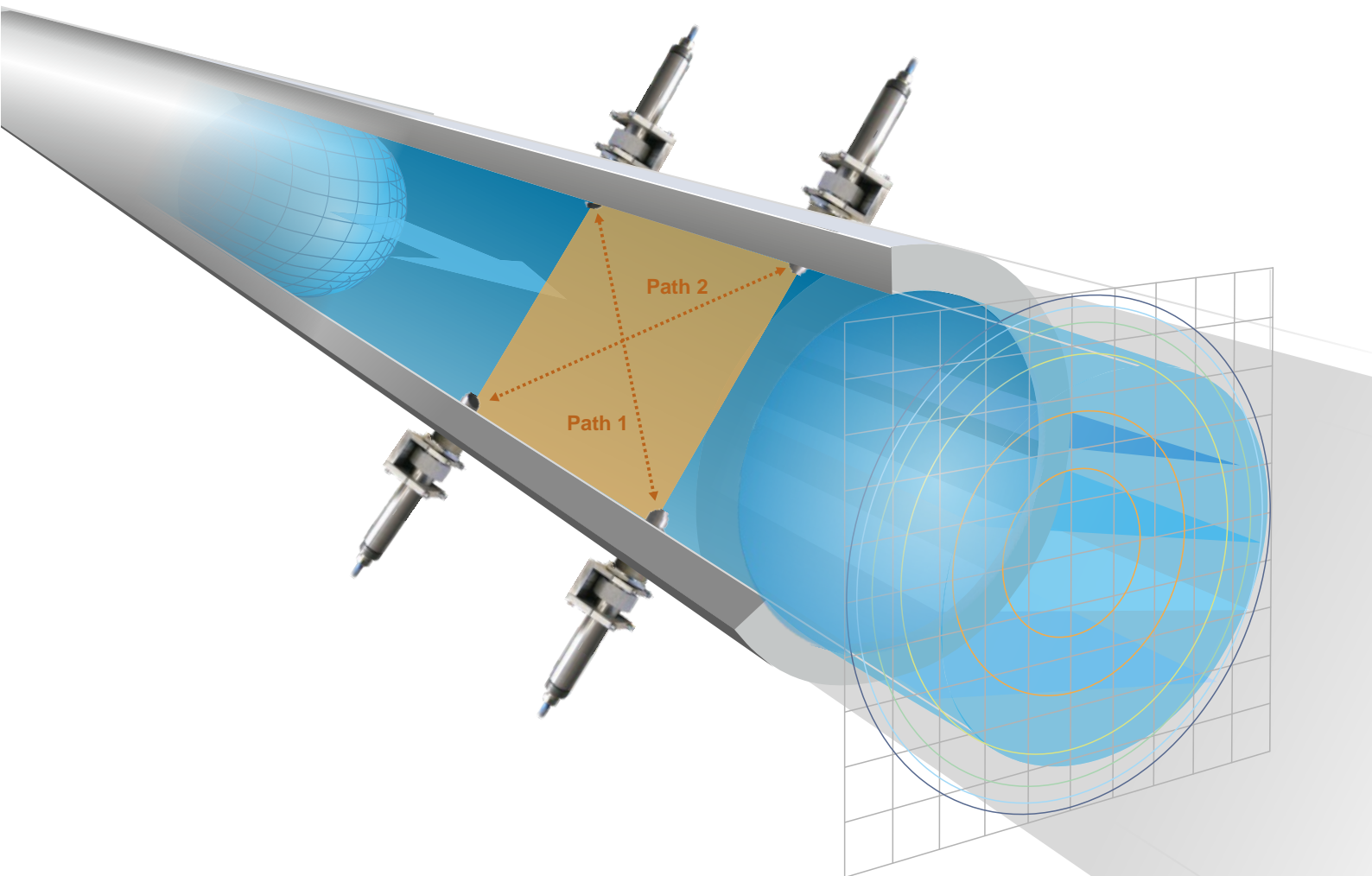

The NivuFlow 600 measurement principle is based on detecting the transit time of ultrasonic signals between two sensors (A and B).

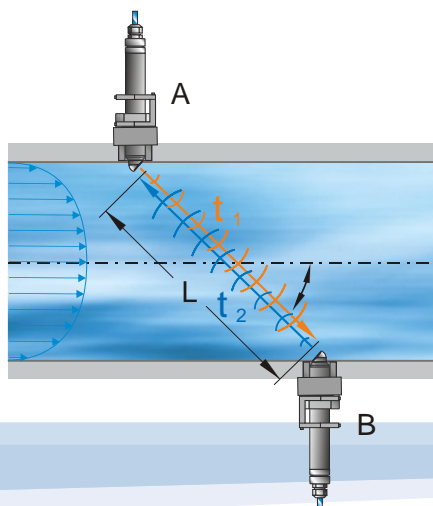

The transit time in flow direction  $t_1$  is shorter than it is against the flow direction  $t_2$ . The difference between both transit times is proportional to the average flow velocity along the measurement path  $v_m$ . The system calculates the average cross-sectional area velocity  $v_A$  from the path velocity  $v_m$  and indicates it directly on the display.

Flow in full pipes is calculated by using the general equation of continuity:

$$Q = A \cdot v_A$$

$A$  = cross-sectional area  
 $v_A$  = average flow velocity in cross-sectional area

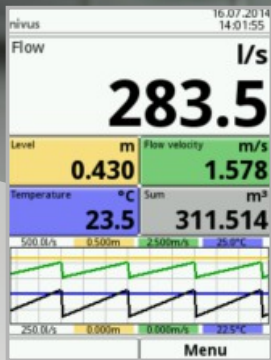

Screen display main screen



Screen display menu

## The Nivu Flow 600 Transmitter

The intuitive one-hand operation and the bright high-resolution colour display allow quick, easy and cost-efficient commissioning on site. Additional input devices or software are not required.

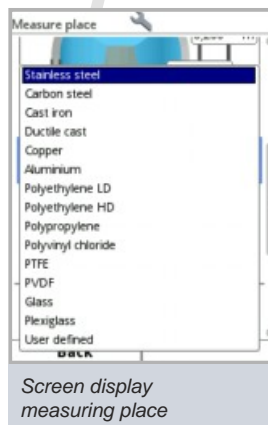

Screen display measuring place

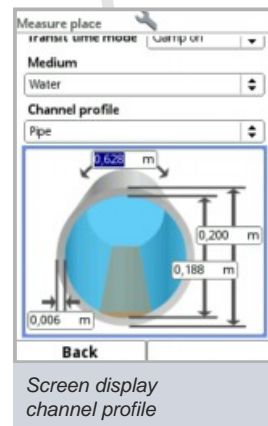

Screen display channel profile



## The right sensor for your application

The complete flow measurement system consists of the NivuFlow 600 transmitter and the appropriate sensors for use in full filled pipes. The NivuFlow 600 can use up to 4 measurement paths.

### Your benefits

- Absolutely zero point stable and drift-free sensors
- Low installation expenses through perfectly matched mounting accessories
- Installation under process conditions
- Various sensor constructions guarantee the best solution for each application
- Digital signal transmission for error-free connections over long distances
- WRAS approved pipe sensors available



Clamp-on-Sensor

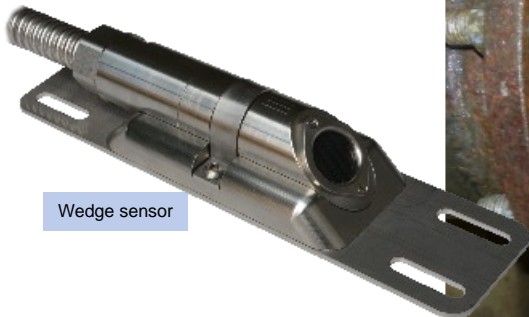
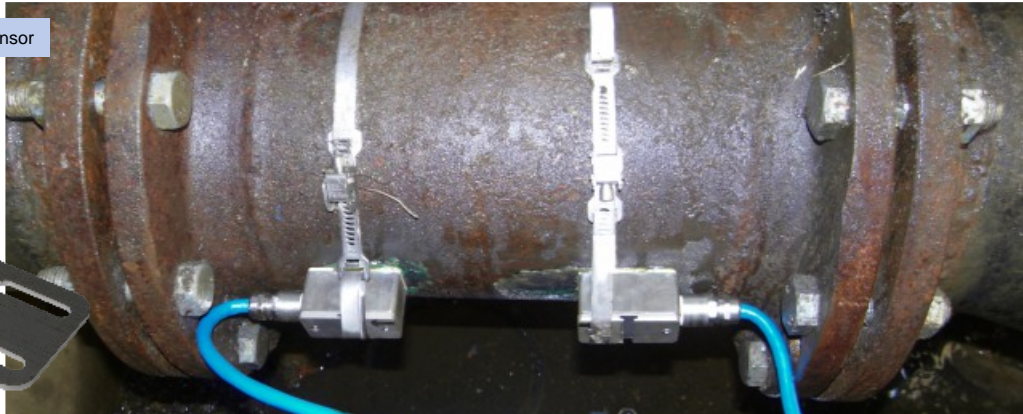

Wedge sensor



Pipe sensors



Pipe sensor for use in drinking water



## Perfect solutions



Turbine intake flow measurement using clamp-on sensors



Nighttime supply flow measurement single path measurement in a full filled pipe



Hydropower plants

## On site from anywhere

- Integrated data logger for high data security
- Saved data can be recalled at any time
- Online operation and online setting of parameters (remote control)
- Quick and comprehensive remote diagnostics of entire measurement places

NivuFlow is available as unit for installation in control cabinets or with a robust field enclosure



Installation suggestion



